



"A 100% Employee-Owned Company"

Engineered Process Solutions (EPS) Duplex Fuel Oil Sets

Cummins-Wagner EPS division is proud to offer duplex fuel oil sets for a wide range of flow rates and pressures.

Our standard skids make use of the Viking 432 Series pumps for flow rates of 0.5-3 GPM at 25-150 PSIG and 5-20 GPM at 25-50 PSIG.

Standard packages include pumps, motors, duplex strainer, external relief valves, isolation valves, check valves, suction and discharge gauges and control panel all mounted on a containment pan. The units are fully assembled, painted, wired and tested.

Basic starter or PLC control panels are available in standard NEMA classifications.

In addition to our standard units, our in-house engineering staff can create a custom package to meet your specific needs.

Cummins-Wagner DPF Series Pump Sets



Note: simplex and triplex configurations also available.

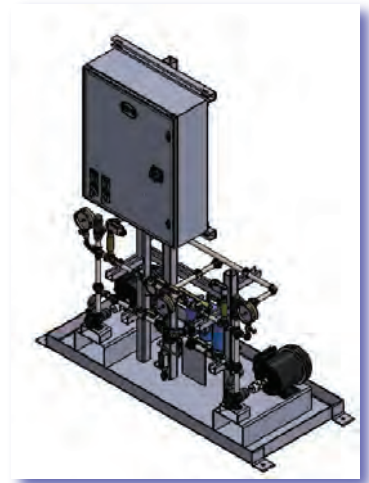

Enclosures



Weather proof, free standing SS cabinet.

In addition to pan mounted pump packages, we offer a weather proof, free standing stainless steel cabinet option and a weather proof, fiberglass enclosure with lighting and heat option. Both options include control panels as well.



Weather proof fiberglass enclosure.

Visit our website: Cummins-Wagner.com



Viking 432 Series Matrix

	25 psig	50 psig	75 psig	100 psig	125 psig	150 psig
0.5 GPM	DPF-0.5-3 Viking C432-X 0.52 GPM @ 25 psi	DPF-0.5-5 Viking C432-X 0.48 GPM @ 50 psi	DPF-0.5-8 Viking C432-X 0.45 GPM @ 75 psi	DPF-0.5-10 Viking C432-X 0.41 GPM @ 100 psi	DPF-0.5-13 Viking C432-X 0.40 GPM @ 125 psi	DPF-0.5-15 Viking C432-X 0.38 GPM @ 150 psi
1 GPM	DPF-1-3 Viking F432-X 1.0 GPM @ 25 psi	DPF-1-5 Viking F432-X 0.91 GPM @ 50 psi	DPF-1-8 Viking F432-X 0.82 GPM @ 75 psi	DPF-1-10 Viking F432-X 0.75 GPM @ 100 psi	DPF-1-13 Viking F432-X 0.69 GPM @ 125 psi	DPF-1-15 Viking F432-X 0.66 GPM @ 150 psi
1.5 GPM	DPF-1.5-3 Viking F432-X 1.6 GPM @ 25 psi	DPF-1.5-5 Viking F432-X 1.5 GPM @ 50 psi	DPF-1.5-8 Viking F432-X 1.4 GPM @ 75 psi	DPF-1.5-10 Viking F432-X 1.4 GPM @ 100 psi	DPF-1.5-13 Viking F432-X 1.3 GPM @ 125 psi	DPF-1.5-15 Viking F432-X 1.3 GPM @ 150 psi
2 GPM	DPF-2-3 Viking FH432-X 1.99 GPM @ 25 psi	DPF-2-5 Viking FH432-X 1.85 GPM @ 50 psi	DPF-2-8 Viking FH432-X 1.73 GPM @ 75 psi	DPF-2-10 Viking FH432-X 1.64 GPM @ 100 psi	DPF-2-13 Viking FH432-X 1.56 GPM @ 125 psi	DPF-2-15 Viking FH432-X 1.48 GPM @ 150 psi
3 GPM	DPF-3-3 Viking FH432-X 3.2 GPM @ 25 psi	DPF-3-5 Viking FH432-X 3.0 GPM @ 50 psi	DPF-3-8 Viking FH432-X 2.9 GPM @ 75 psi	DPF-3-10 Viking FH432-X 2.8 GPM @ 100 psi	DPF-3-13 Viking FH432-X 2.7 GPM @ 125 psi	DPF-3-15 Viking FH432-X 2.7 GPM @ 150 psi
5 GPM	DPF-5-3 Viking G432-X 5.6 GPM @ 25 psi	DPF-5-5 Viking G432-X 5.4 GPM @ 50 psi	Max Pressure 50 psig	Max Pressure 50 psig	Max Pressure 50 psig	Max Pressure 50 psig
10 GPM	DPF-10-3 Viking H432-X 10.1 GPM @ 25 psi	DPF-10-5 Viking H432-X 9.8 GPM @ 50 psi	Max Pressure 50 psig	Max Pressure 50 psig	Max Pressure 50 psig	Max Pressure 50 psig
20 GPM	DPF-20-3 Viking HL432-X 20.5 GPM @ 25 psi	DPF-20-5 Viking HL432-X 20.0 GPM @ 50 psi	Max Pressure 50 psig	Max Pressure 50 psig	Max Pressure 50 psig	Max Pressure 50 psig

Cummins-Wagner EPS (Engineered Process Solutions)

Contact your local Cummins-Wagner branch for more information about our fuel oil sets, or contact the EPS division of Cummins-Wagner at:

(484) 841-6040

or email EPSsales@Cummins-Wagner.com

Let us build your Solution.



The EPS Team.

